

WATERPROOF STRAIGHT PLUG CRIMP+HOUSING

R197.114.Z11

CABLE 2.6/50S

Series : **SMB**
CARLOCK

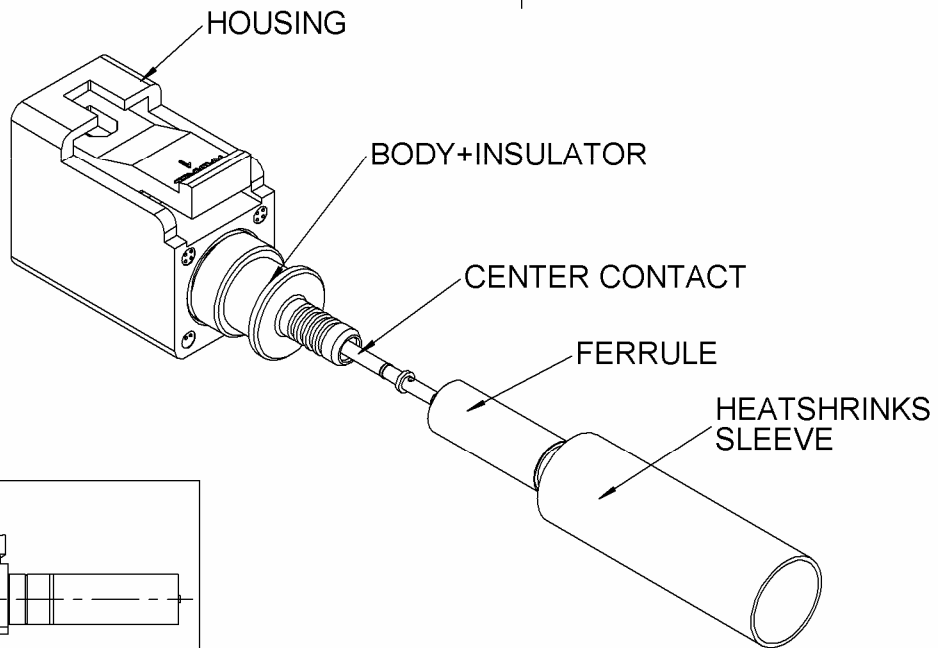
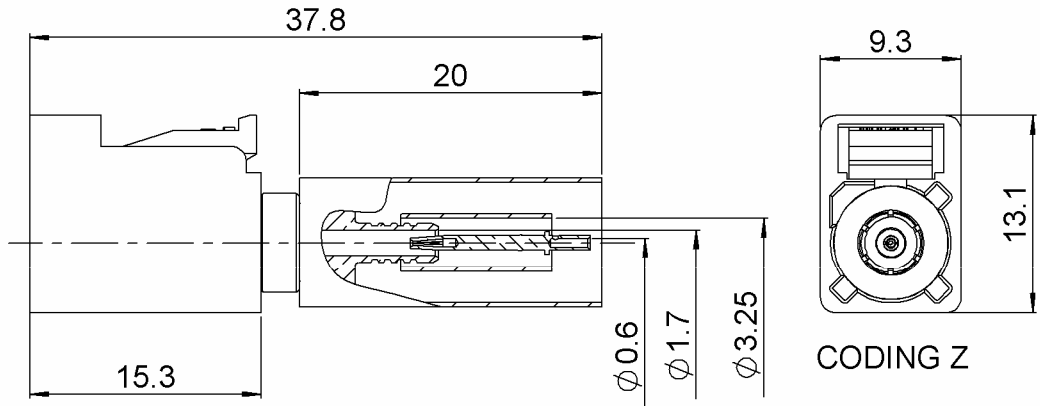

IP67 with the connector R197.134.Z11 only

All dimensions are in mm.

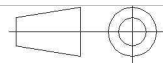

| COMPONENTS | MATERIALS | PLATING (µm) |
|----------------|-----------|-------------------------|
| BODY | BRONZE | NICKEL 2 |
| CENTER CONTACT | BRONZE | -GOLD 0.8 OVER NICKEL 2 |
| OUTER CONTACT | | - |
| INSULATOR | PTFE | |
| GASKET | NBR 70 | |
| OTHERS PARTS | BRASS | NICKEL 2 |
| - | - | - |
| - | - | - |

HOUSING

PA6.6 GF15 (POLYAMIDE)

UL CLASSIFICATION

UL 94 V-2

COLOR

SEE PAGE 3

Issue : 0747 A

In the effort to improve our products, we reserve the right to make changes judged to be necessary.



RADIALL®

WATERPROOF STRAIGHT PLUG CRIMP+HOUSING

R197.114.Z11

CABLE 2.6/50S

Series : **SMB**
CARLOCK

PACKAGING

| Standard | Unit | Other |
|------------|-------------------|-------------------|
| 100 | 'W' option | Contact us |

SPECIFICATION

QS9000

CABLE ASSEMBLY

| Stripping | a | b | c | d | e | f |
|-----------|------|------|------|------|------|------|
| mm | 3.00 | 5.50 | 14.0 | 0.00 | 11.0 | 0.00 |

ELECTRICAL CHARACTERISTICS

| | | |
|---------------------------------|----------------------|--------------------------|
| Impedance | 50 | Ω |
| Frequency | 0-4 | GHz |
| VSWR | 1.20 + 0.0000 | x F(GHz) Maxi |
| Insertion loss | TBD | \sqrt{F} (GHz) dB Maxi |
| RF leakage | - (TBD | - F(GHz)) dB Maxi |
| Voltage rating | 335 | Veff Maxi |
| Dielectric withstanding voltage | 1000 | Veff mini |
| Insulation resistance | 1000 | M Ω mini |

Assembly instruction : **See page 4**

Recommended cable(s)
RG 174
RG 316

Characteristics indicated on this data sheet are those that can be achieved with the highest performance cable. Intrinsic limitations of the cable may diminish the performance of the assembly

Cable retention

- pull off
- RG174 ***65** N mini
- RG316 **110** N mini
- torque **NA** N.cm

MECHANICAL CHARACTERISTICS

| | | |
|----------------------------|-----------|-----------|
| Center contact retention | | |
| Axial force – Mating end | 10 | N mini |
| Axial force – Opposite end | 10 | N mini |
| Torque | | N.cm mini |

TOOLING

| Part Number | Description | Hexagon |
|--------------|------------------------------|----------------------|
| . | . | . |
| R282.235.915 | CRIMPING DIES | Hex 3.25 square 0.72 |
| R282.271.000 | CRIMPING TOOL | Hex 3.25 square 0.72 |
| R282.281.000 | CRIMPING TOOL | 2x4 pts 3pos |
| R282.293.000 | CRIMPING TOOL M22520/5-01 | |
| R282.967.034 | POSITIONER FOR TOOL R282 281 | |

| | | |
|--------------------|---------------|------|
| Recommended torque | | |
| Mating | NA | N.cm |
| Panel nut | NA | N.cm |
| Clamp nut | NA | N.cm |
| A/F clamp nut | 0.0000 | mm |

| | | |
|-------------|---------------|-------------|
| Mating life | 10 | Cycles mini |
| Weight | 3.7700 | g |

ENVIRONMENTAL

| | | |
|-----------------------|-----------------|--------------|
| Operating temperature | *-40/+85 | $^{\circ}$ C |
| Hermetic seal | NA | Atm.cm3/s |
| Panel leakage | IP67 | |

OTHER CHARACTERISTICS

*Depends on the cable used

Issue : **0747 A**

In the effort to improve our products, we reserve the right to make changes judged to be necessary.



WATERPROOF STRAIGHT PLUG CRIMP+HOUSING

R197.114.Z11

CABLE 2.6/50S

Series : **SMB**
CARLOCK

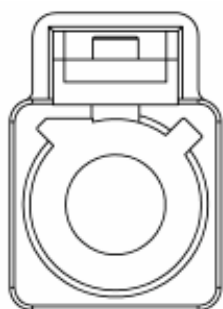

CODING A
COLOR BLACK
RAL 9005

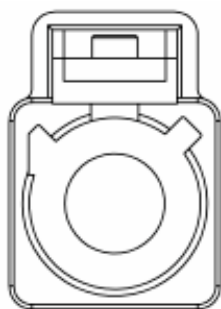

CODING B
COLOR CREAMWHITE
RAL 9001

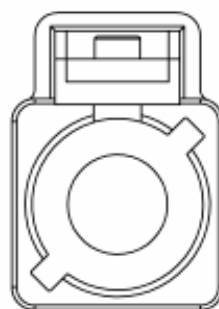

CODING C
COLOR BLUE
RAL 5005

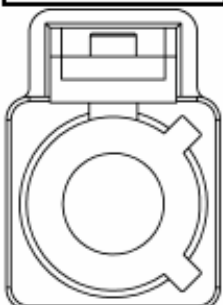

CODING D
COLOR BORDEAUX
VIOLET
RAL 4004

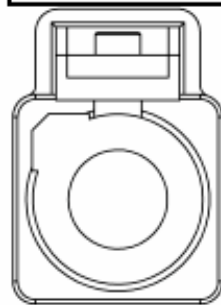

CODING E
COLOR GREEN
RAL 6002

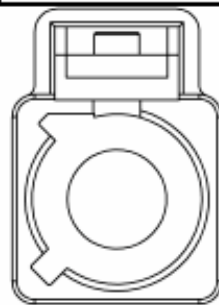

CODING F
COLOR BROWN
RAL 8011

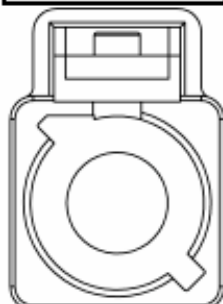

CODING G
COLOR GREY
RAL7031

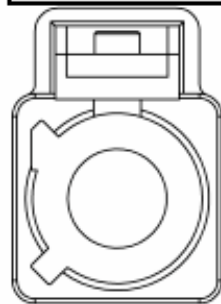

CODING H
COLOR VIOLET
RAL 4003

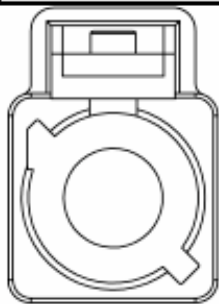

CODING I
COLOR BEIGE
RAL 1001

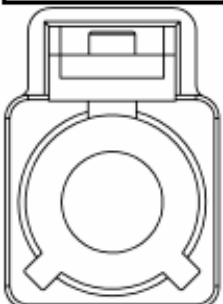

CODING K
COLOR CURRY
RAL 1027

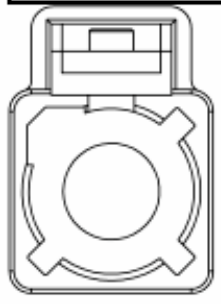

CODING Z
COLOR WATER BLUE
RAL 5021

UL CLASSIFICATION
UL 94V-2

*According to FAKRA specifications

-To obtain the complete P/N please fill in the blank " _ " with the coding letter

Issue : 0747 A

In the effort to improve our products, we reserve the right to make changes judged to be necessary.



RADIALL®

WATERPROOF STRAIGHT PLUG CRIMP+HOUSING

R197.114.Z11

CABLE 2.6/50S

Series : **SMB**
CARLOCK

COMPONENTS

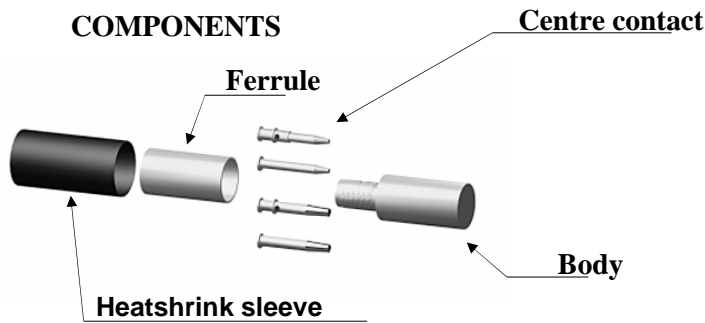

STRIPPING DIMENSIONS

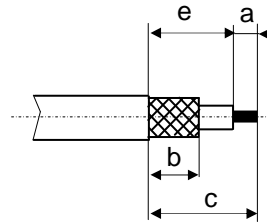

1

Slide the heatshrink sleeve onto the cable.
Slide the ferrule onto the cable.
Strip the cable.

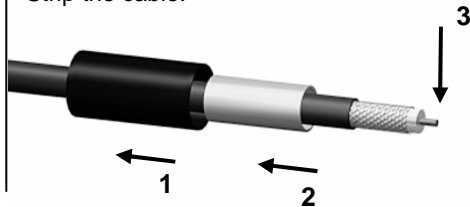

4

Slide the cable into the body until it bottoms against the insulator.

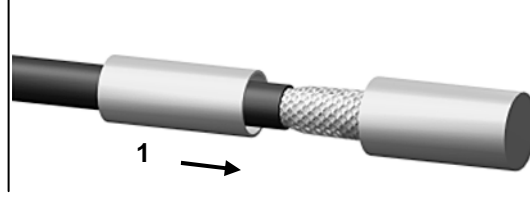

2

Slide the centre contact on until it bottoms against the cable dielectric.
Crimping the center contact with square 0.72



5

Slide the ferrule over the braid.
Crimp the ferrule with crimping tool (see connector TDS).

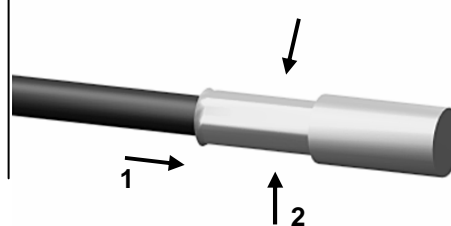

3

Fan the braid.

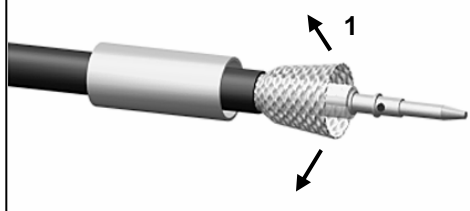

6

Cut the excess of braid if necessary.
Slide the sleeve over the ferrule and heatshrink it in place.

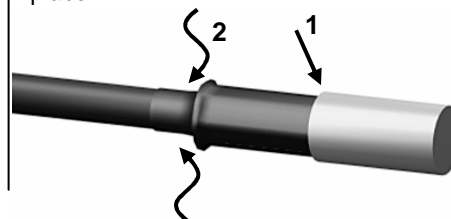

Issue : 0747 A

In the effort to improve our products, we reserve the right to make changes judged to be necessary.

